



HAL
open science

Compact composition operators on Bergman-Orlicz spaces

Pascal Lefèvre, Daniel Li, Hervé Queffélec, Luis Rodriguez-Piazza

► **To cite this version:**

Pascal Lefèvre, Daniel Li, Hervé Queffélec, Luis Rodriguez-Piazza. Compact composition operators on Bergman-Orlicz spaces. 2009. hal-00426831v1

HAL Id: hal-00426831

<https://univ-artois.hal.science/hal-00426831v1>

Preprint submitted on 28 Oct 2009 (v1), last revised 30 Mar 2010 (v2)

HAL is a multi-disciplinary open access archive for the deposit and dissemination of scientific research documents, whether they are published or not. The documents may come from teaching and research institutions in France or abroad, or from public or private research centers.

L'archive ouverte pluridisciplinaire **HAL**, est destinée au dépôt et à la diffusion de documents scientifiques de niveau recherche, publiés ou non, émanant des établissements d'enseignement et de recherche français ou étrangers, des laboratoires publics ou privés.

Compact composition operators on Bergman-Orlicz spaces

*Pascal Lefèvre, Daniel Li,
Hervé Queffélec, Luis Rodríguez-Piazza*

October 28, 2009

Abstract. *We construct an analytic self-map φ of the unit disk and an Orlicz function Ψ for which the composition operator of symbol φ is compact on the Hardy-Orlicz space H^Ψ , but not compact on the Bergman-Orlicz space \mathfrak{B}^Ψ . For that, we first prove a Carleson embedding theorem, and then characterize the compactness of composition operators on Bergman-Orlicz spaces, in terms of Carleson function (of order 2). We show that this Carleson function is equivalent to the Nevanlinna counting function of order 2.*

Mathematics Subject Classification. Primary: 47B33 – Secondary: 30D50; 30D55; 46E15

Key-words. Bergman-Orlicz space – Carleson function – Compactness – Composition operator – Hardy-Orlicz space – Nevanlinna counting function

1 Introduction and notation

1.1 Introduction

Due to the Littlewood subordination principle, the boundedness of composition operators C_φ , defined by $C_\varphi(f) = f \circ \varphi$, on Hardy spaces H^p , as well as on Bergman spaces \mathfrak{B}^p , $1 \leq p \leq \infty$, is automatic. Their compactness is something much more subtle, but is well understood now, and there are two well-separated cases. First, the case $p = \infty$, for which $C_\varphi: H^\infty \rightarrow H^\infty$ is compact if and only if $\|\varphi\|_\infty < 1$ (note that $\mathfrak{B}^\infty = H^\infty$). Secondly, the case $p < \infty$, for which the compactness does not depend on p . For Hardy spaces, this fact, proved by J. Shapiro and P. Taylor ([13]), is not completely trivial, and is due to the good factorization properties of functions in H^p . For the scale of Bergman spaces \mathfrak{B}^p , the factorization properties are not so good, but the independence with respect to p follows from the following characterization ([10], Corollary 4.4): for $1 \leq p < \infty$, $C_\varphi: \mathfrak{B}^p \rightarrow \mathfrak{B}^p$ is compact if and only if the pull-back measure of the area-measure \mathcal{A} by φ is a 2-Carleson measure. The case $p = 2$ (proved in

[1]) gives then, for $1 \leq p < \infty$:

$$(1.1) \quad C_\varphi: \mathfrak{B}^p \rightarrow \mathfrak{B}^p \text{ is compact} \quad \iff \quad \lim_{|z| \rightarrow 1} \frac{1 - |\varphi(z)|}{1 - |z|} = \infty.$$

In both cases (Hardy and Bergman), a brutal change of situation occurs when we pass from finite values of p to the value $p = \infty$, and the need was felt for an intermediate scale between H^p and H^∞ , or between \mathfrak{B}^p and \mathfrak{B}^∞ . This is what we did ([7]), in full detail, with Hardy-Orlicz spaces H^Ψ associated with an Orlicz function Ψ (and began to do for Bergman-Orlicz spaces \mathfrak{B}^Ψ). We introduced a generalization of the notion of Carleson measure, and proved a contractivity property of those Carleson measures $m_\varphi = \varphi^*(m)$, attached to an analytic self-map $\varphi: \mathbb{D} \rightarrow \mathbb{D}$, which turned out to be central to obtain a necessary and sufficient condition for the compactness of $C_\varphi: H^\Psi \rightarrow H^\Psi$. In that paper, we also began a study of the compactness of composition operators on \mathfrak{B}^Ψ . We proved, in particular, but implicitly (see the comments at the beginning of Section 4), that, if the Orlicz function Ψ grows very fast (satisfying the so-called Δ^2 condition), then the compactness of $C_\varphi: H^\Psi \rightarrow H^\Psi$ implies its compactness as an operator $C_\varphi: \mathfrak{B}^\Psi \rightarrow \mathfrak{B}^\Psi$. On the other hand, it is well-known that the compactness on H^p implies the compactness on \mathfrak{B}^p because it is easy to see that the left-hand side of (1.1) is implied by the compactness on H^p . One might think that it is generally easier to achieve compactness on \mathfrak{B}^Ψ than on H^Ψ . The main result of the present work is the existence of an analytic self-map φ of \mathbb{D} and an Orlicz function Ψ such that the composition operator C_φ is compact on H^Ψ but not on \mathfrak{B}^Ψ . For that, we first have to characterize the compactness of composition operators on Bergman-Orlicz spaces. More precisely, the paper is organized as follows.

In Section 2, given two Orlicz functions Ψ_1 and Ψ_2 , and a finite positive measure μ on the unit disk \mathbb{D} , we investigate under which conditions the canonical inclusion $I_\mu: \mathfrak{B}^{\Psi_1} \rightarrow L^{\Psi_2}(\mu)$, defined by $I_\mu(f) = f$, is either bounded, or compact. In Theorem 2.1, we give a *necessary* condition and a *sufficient* condition, in terms of the Carleson function ρ_μ of μ , for the boundedness of I_μ . Analogously, we have a similar statement (Theorem 2.5) for the compactness of I_μ . In general, these necessary and those sufficient conditions do not fit.

In Section 3, we prove one of the main result of this paper (Theorem 3.1) under the form of a contractivity principle for the pull-back measure \mathcal{A}_φ of the planar Lebesgue measure \mathcal{A} on \mathbb{D} by φ . The proof is rather long and uses a Calderón-Zygmund decomposition, as well as an elementary, but very useful, inequality due to Paley and Zygmund. This contractivity principle eliminates the absence of fitness mentioned above and allows us to have a *necessary and sufficient* condition for the compactness of $C_\varphi: \mathfrak{B}^\Psi \rightarrow \mathfrak{B}^\Psi$ in terms of the same Carleson function $\rho_{\mathcal{A}_\varphi} = \rho_{\varphi,2}$ (Theorem 3.2).

In Subsection 3.2, we consider the Nevanlinna counting function $N_{\varphi,2}$ (initiated in [12]), adapted to the Bergman case, and we compare it with the 2-Carleson function $\rho_{\varphi,2}$ of φ . These two functions turn out to be equivalent, in the sense precised in Theorem 3.10. This extends to the Bergman case (and fol-

lows from) such an equivalence for the Hardy case, that we recently established in [8], Theorem 1.1.

Finally, in Section 4, we exploit the necessary and sufficient conditions that we established, either on H^Ψ and on \mathfrak{B}^Ψ , to give (Theorem 4.2) an example of an analytic self-map $\varphi: \mathbb{D} \rightarrow \mathbb{D}$ and of a fairly irregularly varying Orlicz function Ψ such that, contrary to the general intuition, $C_\varphi: H^\Psi \rightarrow H^\Psi$ is compact, whereas $C_\varphi: \mathfrak{B}^\Psi \rightarrow \mathfrak{B}^\Psi$ is not compact. This is due to the fact that we can evaluate, in a fairly way, the two Carleson functions ρ_φ and $\rho_{\varphi,2}$ of φ .

Acknowledgement. The fourth-named author is partially supported by a Spanish research project MTM2006-05622.

1.2 Notation

We shall denote by \mathbb{D} the open unit disk $\{z \in \mathbb{C}; |z| < 1\}$ of the complex plane, and its boundary, the unit circle, by \mathbb{T} . The normalized area measure $d\mathcal{A} = dx dy/\pi$ on \mathbb{D} will be denoted by \mathcal{A} .

For any $\xi \in \mathbb{T}$, we define, for $0 < h < 1$, the Carleson window $W(\xi, h)$ by

$$W(\xi, h) = \{z \in \mathbb{D}; |z| \geq 1 - h \quad \text{and} \quad |\arg(z\bar{\xi})| \leq \pi h\}.$$

We shall also use the ‘‘circular’’ Carleson windows $S(\xi, h)$ defined by $S(\xi, h) = \{z \in \mathbb{D}; |z - \xi| < h\}$. Since $S(\xi, h) \subseteq W(\xi, h) \subseteq S(\xi, 3h)$, measures of $W(\xi, h)$ and of $S(\xi, h)$ are equivalent, up to constants.

For any finite positive measure μ on \mathbb{D} , we define, for $0 < h \leq 1$, the *Carleson function* of μ by:

$$(1.2) \quad \rho_\mu(h) = \sup_{|\xi|=1} \mu(W(\xi, h)),$$

and we set:

$$(1.3) \quad K_{\mu,2}(h) = \sup_{0 < t < h} \frac{\rho_\mu(t)}{t^2}$$

When $\rho_\mu(h) = O(h^2)$, one says that μ is a *2-Carleson measure*; we also say that μ is a *Bergman-Carleson measure*, to insist that the order 2 is adapted to the Bergman spaces. When $\mu = \mathcal{A}_\varphi$ is the pull-back measure of \mathcal{A} by an analytic self-map $\varphi: \mathbb{D} \rightarrow \mathbb{D}$, we shall simply write $\rho_{\varphi,2}$ and $K_{\varphi,2}$ instead of $\rho_{\mathcal{A}_\varphi}$ and $K_{\mathcal{A}_\varphi,2}$ respectively. We shall say that $\rho_{\varphi,2}$ the *2-dimensional Carleson function* of φ .

The Hastings-Luecking sets of size 2^{-n} are defined by:

$$\Delta_k = \left\{ z \in \mathbb{D}; 1 - \frac{1}{2^n} \leq |z| < 1 - \frac{1}{2^{n+1}} \quad \text{and} \quad \frac{(2j-1)\pi}{2^n} \leq \arg z < \frac{(2j+1)\pi}{2^n} \right\},$$

where $k = 2^n + j - 1$, $n \geq 0$, $0 \leq j \leq 2^n - 1$ (note that $\Delta_0 = D(0, 1/2)$).

An Orlicz function Ψ is a positive increasing convex function $\Psi: [0, \infty) \rightarrow [0, \infty)$ such that $\Psi(0) = 0$ (and $\Psi(\infty) = \infty$). If μ is a positive measure on \mathbb{D} , the Orlicz space $L^\Psi(\mu)$ is the space of (classes of) measurable functions $f: \mathbb{D} \rightarrow \mathbb{C}$ such that $\int_{\mathbb{D}} \Psi(|f|/C) d\mathcal{A} < \infty$, for some constant $C > 0$, and the norm $\|f\|_\Psi$ is defined as the infimum of all constants $C > 0$ for which $\int_{\mathbb{D}} \Psi(|f|/C) d\mathcal{A} \leq 1$. The *Bergman-Orlicz space* is the subspace of $L^\Psi(\mathcal{A})$ whose members are analytic in \mathbb{D} .

The Hardy-Orlicz space H^Ψ is the subspace of H^1 whose boundary values are in the Orlicz space $L^\Psi(\mathbb{T}, m)$.

We refer to [3] (see also [5], and [14]) for the theory of Bergman spaces and to [11] for more information about Orlicz spaces.

2 Carleson embeddings

We consider in this Section, the “embedding” map $I_\mu: \mathfrak{B}^{\Psi_1} \rightarrow L^{\Psi_2}(\mu)$, defined by $I_\mu(f) = f$, where μ is an arbitrary finite positive Borel measure on \mathbb{D} and Ψ_1 and Ψ_2 are two Orlicz functions.

2.1 Boundedness

Theorem 2.1 *Given μ a finite positive Borel measure on \mathbb{D} and Ψ_1 and Ψ_2 two Orlicz functions, let $I_\mu: \mathfrak{B}^{\Psi_1} \rightarrow L^{\Psi_2}(\mu)$ be the canonical map defined by $I_\mu(f) = f$. One has:*

1) *If I_μ is bounded, then there is a constant $A > 0$ such that:*

$$(2.1) \quad \rho_\mu(h) \leq \frac{1}{\Psi_2[A\Psi_1^{-1}(1/h^2)]}, \quad \text{for all } 0 < h < 1.$$

2) *In order that I_μ is bounded, it suffices that there is a constant $A > 0$ such that:*

$$(2.2) \quad K_{\mu,2}(h) \leq \frac{1/h^2}{\Psi_2[A\Psi_1^{-1}(1/h^2)]}, \quad \text{for all } 0 < h < 1.$$

Note that condition (2.1) reads as $\frac{\Psi_1^{-1}(1/h^2)}{\Psi_2^{-1}(1/\rho_\mu(h))}$ is bounded (by $1/A$) and condition (2.2) as $\frac{\Psi_1^{-1}(1/h^2)}{\Psi_2^{-1}(1/h^2 K_{\mu,2}(h))}$ is bounded.

When $\Psi_1 = \Psi_2 = \Psi$ and the Orlicz function Ψ satisfies the usual condition Δ_2 : $\Psi(2x) \leq C\Psi(x)$ for some constant $C > 1$ and x large enough, it is clear that conditions (2.1) and (2.2) are equivalent. However, they are not equivalent in general; and even condition (2.1) is not sufficient and condition (2.2) is not necessary: the examples **1.b** and **2.** of [7], Chapter 4, §3, given in the Hardy case, work also for the Bergman case. For the sake of completeness, we are going to sketch them.

Example 1. For every Orlicz function which does not satisfy the Δ_2 condition, there exists a finite positive measure μ on \mathbb{D} such that $I_\mu: \mathfrak{B}^\Psi \rightarrow L^\Psi(\mu)$ is continuous, though μ is not a 2-Carleson measure, and a fortiori does not verify (2.2).

Proof. Since Ψ does not satisfy Δ_2 , there exists an increasing sequence $(a_n)_{n \geq 1}$ such that $\Psi(a_n)/n$ is increasing and $\Psi(2a_n)/\Psi(a_n) \geq n2^n$. Define the discrete measure μ :

$$\mu = \sum_{n=1}^{\infty} \left(\frac{n}{\Psi(2a_n)} - \frac{n+1}{\Psi(2a_{n+1})} \right) \delta_{x_n},$$

where $x_n = 1 - 1/\sqrt{\Psi(2a_n)}$. As $\mu([x_N, 1]) = N/\Psi(2a_N)$, μ is not a 2-Carleson measure. On the other hand, for every f in the unit ball of \mathfrak{B}^Ψ , one has ([7], Lemma 5.2) $|f(z)| \leq 8\Psi^{-1}[1/(1-|z|)^2]$ and it is easy to check that, if $g(z) = \Psi^{-1}[1/(1-|z|)^2]$, then $\|g\|_{L^\Psi(\mu)} \leq 2$, so $\|f\|_{L^\Psi(\mu)} \leq 16$, proving that I_μ is bounded. \square

Example 2. Let $\Psi(x) = e^x - 1$; there exists a finite positive measure μ on \mathbb{D} such that (2.1) holds but $I_\mu: \mathfrak{B}^\Psi \rightarrow L^\Psi(\mu)$ is not bounded.

Proof. Let ν be a probability measure on \mathbb{T} , supported by a compact set L of Lebesgue measure zero, such that $\nu(I) \leq |I|^{1/2}$, for each interval I . We can associate to ν the measure on \mathbb{D} defined by $\tilde{\nu}(E) = \nu(E \cap \mathbb{T})$. By Rudin-Carleson's Theorem, for every integer n , there exists a function g_n in the unit ball of the disk algebra such that $|g_n| = 1$ on L and $\|g_n\|_{H^\Psi} \leq \|g_n\|_\infty \leq 4^{-n}$. As L is compact, there exists some $r_n \in (1/2, 1)$ such that $|g_n(r_n z)| \geq 1/2$ for every $z \in L$. Now, define the measure μ by:

$$\mu(E) = \sum_{n=1}^{\infty} \frac{1}{2^n} \nu_n(E),$$

where:

$$\nu_n(E) = \nu(\{z \in \mathbb{T}; r_n z \in E\}).$$

If W is a Carleson window of size h then, for each $n \geq 1$, we have:

$$\nu(\{z \in \mathbb{T}; r_n z \in W\}) \leq \nu(W \cap \mathbb{T}) \leq (2h)^{1/2}.$$

Hence, $\mu(W) \leq (2h)^{1/2} \lesssim 1/\Psi[\frac{1}{4}\Psi^{-1}(1/h^2)]$, and the condition (2.1) is fulfilled.

Nevertheless, the identity from \mathfrak{B}^Ψ to $L^1(\mu)$ is not continuous since this would imply that the identity from H^Ψ to $L^1(\mu)$ were continuous as well, which is not the case: $\|g_n\|_{L^1(\mu)} \geq 1/2^{n+1}$. \square

In order to prove Theorem 2.1, we shall need some results. They are analogous to Proposition 4.9, Theorem 4.13 and Lemma 4.14 of [7], but their proofs require different arguments¹.

¹ By the way, we seize the opportunity to correct here the proof of Theorem 4.13 given in [7], where some argument had been put awkwardly. In that proof, we first had to set

We first introduce the following maximal function:

$$(2.3) \quad \Lambda_f = \sum_{k=0}^{\infty} \left(\sup_{\Delta_k} |f| \right) \mathbb{1}_{\Delta_k}.$$

One has:

Lemma 2.2 *For every Orlicz function Ψ , the map $f \in \mathfrak{B}^\Psi \mapsto \Lambda_f \in L^\Psi(\mathbb{D})$ is bounded.*

Proof. Set $c_k = \sup_{\Delta_k} |f|$ for every $k \geq 1$, and let $\alpha_k \in \Delta_k$ be such that $|f(\alpha_k)| \geq \frac{1}{2} \sup_{\Delta_k} |f| = c_k/2$. With $C = \|f\|_{\mathfrak{B}^\Psi} > 0$, one has:

$$\int_{\mathbb{D}} \Psi(\Lambda_f/2C) d\mathcal{A} = \sum_{k \geq 0} \Psi(c_k/2C) \mathcal{A}(\Delta_k) \leq \int_{\mathbb{D}} \Psi(|f|/C) d\mu,$$

where $\mu = \sum_{k \geq 0} \mathcal{A}(\Delta_k) \delta_{\alpha_k}$.

But, for every Carleson window W , we can write:

$$\mu(W) = \sum_{\alpha_k \in W} \mathcal{A}(\Delta_k) \leq \sum_{\Delta_k \cap W \neq \emptyset} \mathcal{A}(\Delta_k) = \mathcal{A}\left(\bigcup_{\Delta_k \cap W \neq \emptyset} \Delta_k\right),$$

and, since $\bigcup_{\Delta_k \cap W \neq \emptyset} \Delta_k$ is contained in the window \tilde{W} with the same center as W , but with size two times that of W , one has $\mu(W) \leq \mathcal{A}(\tilde{W}) = 4\mathcal{A}(W)$. Hence μ is a Bergman-Carleson measure. By [4], it follows that, for some constant $C_0 > 0$ (and we shall, as we may, assume that $C_0 \geq 1$), one has, using the subharmonicity of $\Psi(|f|/C)$:

$$\int_{\mathbb{D}} \Psi(|f|/C) d\mu \leq C_0 \int_{\mathbb{D}} \Psi(|f|/C) d\mathcal{A} \leq C_0.$$

Now, by convexity of Ψ , we get:

$$\int_{\mathbb{D}} \Psi\left(\frac{\Lambda_f}{2C_0 \|f\|_{\mathfrak{B}^\Psi}}\right) d\mathcal{A} \leq \int_{\mathbb{D}} \frac{1}{C_0} \Psi\left(\frac{\Lambda_f}{2\|f\|_{\mathfrak{B}^\Psi}}\right) d\mathcal{A} \leq 1,$$

meaning that $\|\Lambda_f\|_{L^\Psi(\mathbb{D})} \leq 2C_0 \|f\|_{\mathfrak{B}^\Psi}$. □

Lemma 2.3 *For every $f \in \mathfrak{B}^1$ and every finite positive Borel measure μ on \mathbb{D} , one has, for $0 < h < 1/2$ and $t > 0$:*

$$\mu(\{z \in \mathbb{D}; |z| > 1 - h \text{ and } |f(z)| > t\}) \leq 4K_{\mu,2}(2h) \mathcal{A}(\{\Lambda_f > t\}).$$

$\mathcal{M} = \{z \in \mathbb{D}; |z| > 1 - h \text{ and } |f(z)| > t\}$. Then, M_f being the non-tangential maximal function of $f \in H^1$, the open set $\{M_f > t\}$ is the disjoint union of a countable family of open arcs $I_j \subseteq \mathbb{T}$, and we had to say that every z such that $|f(z)| > t$ belongs to some window $W(I_j)$ (see [2], page 39).

Proof. Remark that when $z \in \Delta_k$ and $|z| > 1 - h$, we must have $1 - 2^{-n-1} > |z| > 1 - h$, hence $h > 2^{-n-1}$; since $k = 2^n + j - 1 \geq 2^{n-1}$, we must have $k \geq 1/4h$. Let $I = \{k \geq 1; \sup_{\Delta_k} |f| > t\}$ and $I_h = \{k \geq 1/4h; \sup_{\Delta_k} |f| > t\}$. If W_k is the smallest Carleson window containing Δ_k , we have:

$$\begin{aligned} & \mu(\{z \in \mathbb{D}; |z| > 1 - h \text{ and } |f(z)| > t\}) \\ & \leq \sum_{k \in I_h} \mu(\Delta_k) \leq \sum_{k \in I_h, k \geq 1/4h} \mu(W_k) \\ & \lesssim \sum_{k \in I_h} K_{\mu,2}(2h) \mathcal{A}(W_k) \leq 4 \sum_{k \in I_h} K_{\mu,2}(2h) \mathcal{A}(\Delta_k) \\ & \leq 4K_{\mu,2}(2h) \sum_{k \in I} \mathcal{A}(\Delta_k) = 4K_{\mu,2}(2h) \mathcal{A}(\{\Lambda_f > t\}). \end{aligned}$$

and Lemma 2.3 is proved. \square

Lemma 2.4 *Let μ be a finite Borel measure on \mathbb{D} and Ψ_1 and Ψ_2 two Orlicz functions.*

We suppose that, for some positive constant A , there is $0 < h_A \leq 1/2$ such that

$$K_{\mu,2}(h) \leq \frac{1/h^2}{\Psi_2[A\Psi_1^{-1}(1/h^2)]}, \text{ for } 0 < h < h_A.$$

Then, for every $f \in \mathfrak{B}^{\Psi_1}$ such that $\|f\|_{\mathfrak{B}^{\Psi_1}} \leq 1$ and every Borel subset E of \mathbb{D} , one has, with $x_A = (A/64)\Psi_1^{-1}(4/h_A^2)$:

$$\int_E \Psi_2(A|f|/64) d\mu \leq \mu(E)\Psi_2(x_A) + \frac{1}{8} \int_{\mathbb{D}} \Psi_1(\Lambda_f) dA.$$

Proof. For every $s > 0$, the inequality $|f(z)| > s$ implies that the norm of the evaluation δ_z at z is greater than s . But this norm is ([7], Lemma 5.2) $\Psi_1(1/(1 - |z|)^2)$, up to constants; more precisely:

$$\|\delta_z\| \leq 8\Psi_1^{-1}\left(\frac{1}{(1 - |z|)^2}\right).$$

Hence, we have:

$$s < 8\Psi_1^{-1}\left(\frac{1}{(1 - |z|)^2}\right),$$

so:

$$|z| > 1 - \frac{1}{\sqrt{\Psi_1(s/8)}}.$$

Lemma 2.3 gives, when $\Psi_1(s/8) \geq 2$:

$$\begin{aligned} \mu(\{|f(z)| > s\}) &= \mu(\{|z| > 1 - \frac{1}{\sqrt{\Psi_1(s/8)}} \text{ and } |f(z)| > s\}) \\ &\leq 4K_{\mu,2}\left(\frac{2}{\sqrt{\Psi_1(s/8)}}\right) \mathcal{A}(\{\Lambda_f > s\}). \end{aligned}$$

But, by our assumption,

$$\begin{aligned}
K_{\mu,2}\left(\frac{2}{\sqrt{\Psi_1(s/8)}}\right) &\leq \frac{\Psi_1(s/8)/4}{\Psi_2[A\Psi_1^{-1}((\Psi_1(s/8)/4))]} \\
&\leq \frac{\Psi_1(s/8)/4}{\Psi_2[(A/4)\Psi_1^{-1}((\Psi_1(s/8)))]} \quad (\text{by convexity}) \\
&= \frac{1}{4} \frac{\Psi_1(s/8)}{\Psi_2(As/32)};
\end{aligned}$$

hence:

$$\mu(\{|f(z)| > s\}) \leq \frac{\Psi_1(s/8)}{\Psi_2(As/32)} \mathcal{A}(\{\Lambda_f > s\}).$$

We get therefore:

$$\begin{aligned}
\int_E \Psi_2(A|f|/64) d\mu &= \int_0^{+\infty} \Psi_2'(t) \mu(\{|f| > 64t/A\} \cap E) dt \\
&\leq \int_0^{x_A} \Psi_2'(t) \mu(E) dt \\
&\quad + \int_{x_A}^{+\infty} \Psi_2'(t) \frac{\Psi_1(8t/A)}{\Psi_2(2t)} \mathcal{A}(\{\Lambda_f > 64t/A\}) dt \\
&\leq \Psi_2(x_A) \mu(E) \\
&\quad + \int_{x_A}^{+\infty} \frac{\Psi_2'(t)}{\Psi_2(2t)} \Psi_1(8t/A) \mathcal{A}(\{\Lambda_f > 64t/A\}) dt.
\end{aligned}$$

But, as Ψ_1 and Ψ_2 are Orlicz functions, one has $t\Psi_2'(t) \leq \Psi_2(2t)$ and $\Psi_1(8t/A) \leq (8t/A)\Psi_1'(8t/A)$; hence:

$$\begin{aligned}
\int_{x_A}^{+\infty} \frac{\Psi_2'(t)}{\Psi_2(2t)} \Psi_1(8t/A) \mathcal{A}(\{\Lambda_f > 64t/A\}) dt \\
&\leq \int_0^{+\infty} \frac{\Psi_1(8t/A)}{t} \mathcal{A}(\{\Lambda_f > 64t/A\}) dt \\
&\leq \frac{8}{A} \int_0^{+\infty} \Psi_1'(8t/A) \mathcal{A}(\{\Lambda_f > 64t/A\}) dt \\
&= \int_0^{+\infty} \Psi_1'(x) \mathcal{A}(\{\Lambda_f > 8x\}) dx \\
&= \int_{\mathbb{D}} \Psi_1(\Lambda_f/8) d\mathcal{A} \leq \frac{1}{8} \int_{\mathbb{D}} \Psi_1(\Lambda_f) d\mathcal{A},
\end{aligned}$$

and the proof of Lemma 2.4 is finished. □

Proof of Theorem 2.1. 1) Consider, for every $a \in \mathbb{D}$, the Berezin kernel:

$$(2.4) \quad H_a(z) = \frac{(1 - |a|^2)^2}{|1 - \bar{a}z|^4}.$$

One has $\|H_a\|_1 = 1$ and

$$\|H_a\|_\infty = \frac{(1 - |a|^2)^2}{(1 - |a|)^4} = \frac{(1 + |a|)^2}{(1 - |a|)^2} \leq \frac{4}{(1 - |a|)^2};$$

hence ([7], Lemma 3.9):

$$(2.5) \quad \|H_a\|_{\mathfrak{B}^{\Psi_1}} \leq \frac{4/h^2}{\Psi_1^{-1}(4/h^2)}, \quad h = 1 - |a|.$$

It follows that the function $f_a = \frac{1}{4} h^2 \Psi_1^{-1}(4/h^2) H_a$ is in the unit ball of \mathfrak{B}^{Ψ_1} .

Now, let $\xi \in \mathbb{T}$ and $0 < h < 1$. When $z \in W(\xi, h)$, one has easily (see [7], proof of Theorem 4.10, with a slightly different definition of $W(\xi, h)$): $|1 - \bar{a}z| \leq 5h$, where $a = (1 - h)\xi$. It follows that then $|f_a(z)| \geq (1/2500)\Psi_1^{-1}(4/h^2)$. Hence:

$$1 \geq \int_{\mathbb{D}} \Psi_2\left(\frac{|f_a|}{\|I_\mu\|}\right) d\mu \geq \Psi_2\left(\frac{1}{2500\|I_\mu\|} \Psi_1^{-1}(4/h^2)\right) \mu(W(\xi, h)),$$

which is (2.1).

2) By Lemma 2.2, there is a constant $C > 0$, that we may, and do, assume ≥ 1 , such that $\|\Lambda_f\|_{L^{\Psi_2}(\mu)} \leq C \|f\|_{\mathfrak{B}^{\Psi_1}}$ for every $f \in \mathfrak{B}^{\Psi_1}$. Let g be in the unit ball of \mathfrak{B}^{Ψ_1} , and apply Lemma 2.4 to $f = g/C$ (whose norm is ≤ 1 yet), $E = \mathbb{D}$, with $h_A = 1/2$; we get, with $\tilde{C} = \max(1, \mu(\mathbb{D})\Psi_2(x_A) + \frac{1}{8})$:

$$\begin{aligned} \int_{\mathbb{D}} \Psi_2\left(\frac{A}{64C\tilde{C}} |g|\right) d\mu &\leq \frac{1}{\tilde{C}} \int_{\mathbb{D}} \Psi_2\left(\frac{A}{64C} |g|\right) d\mu \\ &\leq \frac{1}{\tilde{C}} \left[\mu(\mathbb{D})\Psi_2(x_A) + \frac{1}{8} \int_{\mathbb{D}} \Psi_1(\Lambda_f/C) dA \right] \\ &\leq \frac{1}{\tilde{C}} \left[\mu(\mathbb{D})\Psi_2(x_A) + \frac{1}{8} \right] \leq 1, \end{aligned}$$

which means that $\|g\|_{L^{\Psi_2}(\mu)} \leq 64C\tilde{C}/A$. □

2.2 Compactness

Theorem 2.5 *Let μ be a finite positive Borel measure on \mathbb{D} , Ψ_1 and Ψ_2 two Orlicz functions, and let $I_\mu: \mathfrak{B}^{\Psi_1} \rightarrow L^{\Psi_2}(\mu)$ be the canonical map defined by $I_\mu(f) = f$. One has:*

1) *If I_μ is compact, then:*

$$(2.6) \quad \lim_{h \rightarrow 0} \frac{\Psi_1^{-1}(1/h^2)}{\Psi_2^{-1}(1/\rho_\mu(h))} = 0.$$

2) *In order that I_μ is compact, it suffices that*

$$(2.7) \quad \lim_{h \rightarrow 0} \frac{\Psi_1^{-1}(1/h^2)}{\Psi_2^{-1}(1/h^2 K_{\mu,2}(h))} = 0.$$

As for the boundedness case, conditions (2.6) and (2.7) are equivalent if $\Psi_1 = \Psi_2 = \Psi$ is sufficiently regular, but not in general. We shall give examples after the proof of the theorem, at the end of the section.

To prove the first part of this theorem, we shall need the following lemma.

Lemma 2.6 $I_\mu: \mathfrak{B}^{\Psi_1} \rightarrow L^{\Psi_2}(\mu)$ is compact if and only if for every bounded sequence $(f_n)_n$ in \mathfrak{B}^{Ψ_1} converging to 0 uniformly on compact subsets of \mathbb{D} , the sequence $(I_\mu(f_n))_n$ converges to 0 in the norm of $L^{\Psi_2}(\mu)$.

Proof of Lemma 2.6. Assume that I_μ is compact, and let $(f_n)_n$ be a bounded sequence in \mathfrak{B}^{Ψ_1} which converges to 0 uniformly on compact subsets of \mathbb{D} . Since I_μ is compact and $(f_n)_n$ is bounded, we have a subsequence $(g_n)_n$ such that $g_n = I_\mu(f_n)$ converges to some $g \in L^{\Psi_2}(\mu)$. Then some subsequence of $(g_n)_n$ converges μ -a.e. to g . Since $(g_n)_n$ converges to 0 uniformly on compact subsets of \mathbb{D} , we must have $g = 0$ μ -a.e., that is $g = 0$ as an element of $L^{\Psi_2}(\mu)$. Now, the compactness of I_μ implies that $\|f_n\|_{L^{\Psi_2}(\mu)}$ tends to 0.

Conversely, assume that the condition of the lemma is satisfied, and let $(f_n)_n$ be an arbitrary bounded sequence in \mathfrak{B}^{Ψ_1} . Since the evaluation map is continuous on \mathfrak{B}^{Ψ_1} ([7], Lemma 5.2), $(f_n)_n$ is a normal family, and Montel's Theorem gives a subsequence $(g_n)_n$ which converges uniformly on compact subsets, to some holomorphic function g . By Fatou's lemma, g belongs to \mathfrak{B}^{Ψ_1} . Now, $(g_n - g)_n$ is a bounded sequence of \mathfrak{B}^{Ψ_1} which converges to 0 uniformly on compact subsets of \mathbb{D} . By hypothesis, $\|g_n - g\|_{L^{\Psi_2}(\mu)}$ tends to 0, and it follows that I_μ is compact. \square

Proof of Theorem 2.5. 1) Assume that the map $I_\mu: \mathfrak{B}^{\Psi_1} \rightarrow L^{\Psi_2}(\mu)$ is compact. Consider, for every $a \in \mathbb{D}$, the Berezin kernel (2.4). It follows from (2.4) and (2.5) that $H_a/\|H_a\|_{\mathfrak{B}^{\Psi_1}}$ converges uniformly to 0 on compact subsets of \mathbb{D} as $|a|$ goes to 1; hence, by Lemma 2.6, the compactness of I_μ implies that $\|(H_a/\|H_a\|_{\mathfrak{B}^{\Psi_1}})\|_{L^{\Psi_2}(\mu)}$ tends to 0. That means that, for every $\varepsilon > 0$, one has:

$$\int_{\mathbb{D}} \Psi_2\left(\frac{|H_a|}{\varepsilon\|H_a\|_{\mathfrak{B}^{\Psi_1}}}\right) d\mu \leq 1,$$

for $|a|$ close enough to 1, depending on ε .

Now, let $\xi \in \mathbb{T}$ and $0 < h < 1$; with $a = (1 - h)\xi$. As already said in the proof of Theorem 2.1, $z \in W(\xi, h)$ implies that $|H_a(z)| \geq 1/625h^2$. Therefore:

$$\int_{\mathbb{D}} \Psi_2\left(\frac{|H_a|}{\varepsilon\|H_a\|_{\mathfrak{B}^{\Psi_1}}}\right) d\mu \geq \Psi_2\left(\frac{1/625h^2}{\varepsilon(4/h^2)/\Psi_1^{-1}(4/h^2)}\right) \mu(W(\xi, h)).$$

We get, for $h > 0$ small enough:

$$\mu(W(\xi, h)) \leq \frac{1}{\Psi_2((1/2500\varepsilon)\Psi_1^{-1}(4/h^2))}.$$

Since $\xi \in \mathbb{T}$ is arbitrary, it follows that, for $h > 0$ small enough:

$$\rho_\mu(h) \leq \frac{1}{\Psi_2((1/2500\varepsilon)\Psi_1^{-1}(4/h^2))},$$

which reads:

$$\frac{\Psi_1^{-1}(4/h^2)}{\Psi_2^{-1}(1/\rho_\mu(h))} \leq 2500\varepsilon.$$

Since $\Psi_1^{-1}(4/h^2) \geq \Psi_1^{-1}(1/h^2)$, we have obtained (2.6). \square

2) Assume now that (2.7) is satisfied. By Lemma 2.6, we have to show that for every sequence $(f_n)_n$ in the unit ball of \mathfrak{B}^{Ψ_1} which converges uniformly to 0 on compact subsets of \mathbb{D} , $(I_\mu(f))_n$ converges to 0 for the norm of $L^{\Psi_2}(\mu)$. So, let $(f_n)_n$ be such a sequence, and let $\varepsilon > 0$.

By Lemma 2.2, there is a constant $C \geq 1$ such that $\|\Lambda_f\|_{L^{\Psi_2}(\mu)} \leq C \|f\|_{\mathfrak{B}^{\Psi_1}}$ for every $f \in \mathfrak{B}^{\Psi_1}$. Set $A = 64C/\varepsilon$. By (2.7), there is an $h_A < 1$ such that, for $0 < h \leq h_A$, one has $\Psi^{-1}(1/h^2) \leq (1/A) \Psi_2^{-1}(1/h^2 K_{\mu,2}(h))$, *i.e.*

$$K_{\mu,2}(h) \leq \frac{1/h^2}{\Psi_2[A\Psi_1^{-1}(1/h^2)]}.$$

For $0 < r < 1$, we may therefore apply, for every $n \geq 1$, Lemma 2.4 to f_n/C (which is in the unit ball of \mathfrak{B}^{Ψ_1} , with $E = \mathbb{D} \setminus r\overline{\mathbb{D}}$; we get:

$$\begin{aligned} \int_{\mathbb{D} \setminus r\overline{\mathbb{D}}} \Psi_2(|f_n|/\varepsilon) d\mu &= \int_{\mathbb{D} \setminus r\overline{\mathbb{D}}} \Psi_2(A|f_n|/64C) d\mu \\ &\leq \mu(\mathbb{D} \setminus r\overline{\mathbb{D}}) \Psi_2(x_A) + \frac{1}{8} \int_{\mathbb{D}} \Psi_1(\Lambda_{f_n}/C) d\mathcal{A} \\ &\leq \mu(\mathbb{D} \setminus r\overline{\mathbb{D}}) \Psi_2(x_A) + \frac{1}{8}. \end{aligned}$$

But this last quantity is $\leq 1/2$ for r small enough.

Fix such an $r < 1$. Since $(f_n)_n$ converges uniformly to 0 on compact subsets of \mathbb{D} , one has $\int_{r\overline{\mathbb{D}}} \Psi_2(|f_n|/\varepsilon) d\mu \leq 1/2$ pour n large enough.

It follows that $\int_{\mathbb{D}} \Psi_2(|f_n|/\varepsilon) d\mu \leq 1$, and hence $\|f_n\|_{L^{\Psi_2}(\mu)} \leq \varepsilon$, for n large enough.

That ends the proof of Theorem 2.5. \square

As we said, in general, condition (2.6) is not sufficient to ensure compactness, and condition (2.7) is not necessary. They are equivalent (and hence necessary and sufficient for compactness) if $\Psi_1 = \Psi_2 = \Psi$ and Ψ is a *regular* Orlicz function. Here, *regular* means that Ψ satisfies the condition we called ∇_0 : for some $x_0 > 0$ and some $C \geq 1$, one has $\frac{\Psi(2x)}{\Psi(x)} \leq \frac{\Psi(2Cy)}{\Psi(y)}$ for $x_0 \leq x \leq y$ (see [7], Theorem 4.11, whose proof works as well in the Bergman case). However, we gave in [7], examples showing, in the Hardy case, that this is not always the case (examples **3** and **4** in [7], Chapter 4, §3). These examples work in the Bergman case and we are going to recall them sketchily.

Example 1. For every Orlicz function Ψ not satisfying ∇_0 , there exists a measure μ such that $I_\mu: \mathfrak{B}^\Psi \rightarrow L^\Psi(\mu)$ is compact but for which (2.7) is not satisfied.

Proof. Since $\Psi \notin \nabla_0$, we can select two increasing sequences $(x_n)_{n \geq 1}$ and $(y_n)_{n \geq 1}$, with $1 \leq x_n \leq y_n \leq x_{n+1}$ and $\Psi(x_n) > 1$, such that $\lim x_n = +\infty$ and

$$\frac{\Psi(2x_n)}{\Psi(x_n)} \geq \frac{\Psi(2^n y_n)}{\Psi(y_n)}.$$

Define the discrete measure

$$\mu = \sum_{n=1}^{\infty} \frac{1}{\Psi(2^n y_n)} \delta_{r_n},$$

where $r_n = 1 - 1/\sqrt{\Psi(y_n)}$. The series converge since $\Psi(2^n y_n) \geq 2^n$.

The same proof as in [7] shows that I_μ is compact, but, writing $h_n = 1/\sqrt{\Psi(x_n)}$ and $t_n = \sqrt{\Psi(y_n)}$, we have:

$$K_{\mu,2}(h_n) \geq \frac{\mu([1-t_n, 1])}{t_n^2} \geq \frac{\Psi(y_n)}{\Psi(2^n y_n)} \geq \frac{\Psi(x_n)}{\Psi(2x_n)} = \frac{1/h_n^2}{\Psi(2\Psi^{-1}(1/h_n^2))},$$

showing that (2.7) is not satisfied. □

This actually shows that condition $\Psi \in \nabla_0$ is necessary and sufficient in order to have that the identity from B^Ψ to $L^\Psi(\mu)$ is compact if and only if μ satisfies (2.7).

Example 2. There exist an Orlicz function Ψ and a measure μ on \mathbb{D} such that (2.6) holds, but for which $I_\mu: \mathfrak{B}^\Psi \rightarrow L^\Psi(\mu)$ is not compact.

Proof. We shall use the Orlicz function Ψ introduced in [6]. The key properties of this function are:

- 1) $\Psi(x) \geq x^3/3$ for every $x > 0$;
- 2) $\Psi(k!) \leq (k!)^3$ for every integer $k \geq 1$;
- 3) $\Psi(3(k!)) > k.(k!)^3$ for every integer $k \geq 1$.

Define $x_k = k!$, $y_k = (k+1)!/k^{1/3}$, $r_k = 1 - 1/\sqrt{\Psi(y_k)}$ and $\rho_k = 1 - 1/\sqrt{\Psi(x_k)}$. Of course, $x_2 < y_2 < x_3 < \dots$. Let ν be the discrete measure defined by:

$$\nu = \sum_{k=2}^{\infty} \nu_k,$$

where:

$$\nu_k = \frac{1}{\Psi((k+1)!)} \sum_{a^{k^2}=1} \delta_{r_k a}.$$

In order to show that (2.6) is satisfied, it is clearly sufficient to prove that, when $1/\sqrt{\Psi(y_k)} \leq h < 1/\sqrt{\Psi(y_{k-1})}$ (with $k \geq 3$), we have:

$$\rho_\nu(h) \leq \frac{1}{\Psi(\frac{1}{2}k^{1/3}\Psi^{-1}(1/h^2))}.$$

But, for such h , we have $\Psi^{-1}(1/h^2) \leq y_k$ so

$$\Psi\left(\frac{1}{2}k^{1/3}\Psi^{-1}(1/h^2)\right) \leq \frac{1}{2}\Psi((k+1)!).$$

Hence, the conclusion follows from the fact that $\rho_\nu(h) \leq 2/\Psi((k+1)!)$ (see [7] for more details). So, condition (2.6) is fulfilled.

We now introduce $f_k(z) = x_k \left(\frac{1-\rho_k}{1-\rho_k z^{k^2}}\right)^4$. By (2.5), $\|f_k\|_{\mathfrak{B}^\Psi} \leq 1$. An easy computation gives $r_k^{k^2} \geq \rho_k$, for every $k \geq 2$; so, for every $a \in \mathbb{T}$ with $a^{k^2} = 1$, we have:

$$f_k(ar_k) \geq x_k \left(\frac{1-\rho_k}{1-\rho_k^2}\right)^4 \geq \frac{1}{16}x_k.$$

Hence:

$$\begin{aligned} \int_{\mathbb{D} \setminus r_{k-1}\mathbb{D}} \Psi(48|f_k|) d\nu &\geq \int_{\mathbb{D} \setminus r_{k-1}\mathbb{D}} \Psi(48|f_k|) d\nu_k \geq \frac{k^2}{\Psi((k+1)!)} \Psi(3x_k) \\ &> \frac{k^2}{\Psi((k+1)!)} (k \cdot (k!)^3) \geq 1. \end{aligned}$$

Therefore, we conclude that $\sup_{\|f\|_{\mathfrak{B}^\Psi} \leq 1} \|f\|_{L^\Psi(\mathbb{D} \setminus r_k\mathbb{D}, \mu)} \geq 1/48$, though $r_k \rightarrow 1$. Hence (see the above proof of Theorem 2.5), I_μ is not compact. \square

3 Compactness for composition operators

3.1 Carleson function

We know ([7], Proposition 5.4), that every analytic self-map $\varphi: \mathbb{D} \rightarrow \mathbb{D}$ induces a bounded composition operator $C_\varphi: \mathfrak{B}^\Psi \rightarrow \mathfrak{B}^\Psi$. The main result of this section is that, for the pull-back measure \mathcal{A}_φ of \mathcal{A} by φ , the necessary and the sufficient conditions of Theorem 2.5 are equivalent. The same kind of result occurs for Hardy-Orlicz spaces ([7], Theorem 4.18 and Theorem 4.19), but the proofs must be different (because we use the analytic functions themselves, and not their boundary values).

We have the following contractivity (or homogeneity) result.

Theorem 3.1 *There exists a constant $C_0 > 0$ such that, for every analytic self-map $\varphi: \mathbb{D} \rightarrow \mathbb{D}$, one has:*

$$(3.1) \quad \mathcal{A}(\{\varphi \in S(\xi, \varepsilon h)\}) \leq C_0 \varepsilon^2 \mathcal{A}(\{\varphi \in S(\xi, h)\})$$

for every $\xi \in \mathbb{T}$, $0 < h < (1 - |\varphi(0)|)$, and $0 < \varepsilon \leq 1$.

As a consequence, one has $\rho_{\varphi,2}(\varepsilon h) \leq C \varepsilon^2 \rho_{\varphi,2}(h)$, for $h > 0$ small enough, and hence:

$$\frac{\rho_{\varphi,2}(h)}{h^2} \leq K_{\mu,2}(h) = \sup_{0 < \varepsilon \leq 1} \frac{\rho_{\varphi,2}(\varepsilon h)}{\varepsilon^2 h^2} \leq C_\alpha \frac{\rho_{\varphi,2}(h)}{h^2}.$$

Therefore:

Theorem 3.2 For every analytic self-map $\varphi: \mathbb{D} \rightarrow \mathbb{D}$ and every Orlicz function Ψ , the composition operator $C_\varphi: \mathfrak{B}^\Psi \rightarrow \mathfrak{B}^\Psi$ is compact if and only if

$$(3.2) \quad \lim_{h \rightarrow 0} \frac{\Psi^{-1}(1/h^2)}{\Psi^{-1}(1/\rho_{\varphi,2}(h))} = 0.$$

Proof of Theorem 3.1. It suffices, even if it means enlarging C_0 , to show (3.1) for $0 < h \leq h_0 = \alpha_0(1-|\varphi(0)|)$ and $0 < \varepsilon \leq \varepsilon_0$ for some $0 < \alpha_0 < 1$ and $0 < \varepsilon_0 < 1$. Indeed, if $0 < h \leq h_0$ and $\varepsilon_0 \leq \varepsilon \leq 1$, one has $\mathcal{A}(S(\xi, \varepsilon h)) \leq \mathcal{A}(S(\xi, h)) \leq (1/\varepsilon_0^2)\varepsilon^2 \mathcal{A}(S(\xi, h))$. Now, for $h_0 \leq h < 1 - |\varphi(0)|$, one has, on one hand, for $0 < \varepsilon \leq \alpha_0$, $\mathcal{A}(S(\xi, \varepsilon h)) \leq \mathcal{A}(S(\xi, (\varepsilon/\alpha_0)h_0)) \leq C_0(\varepsilon^2/\alpha_0^2) \mathcal{A}(S(\xi, h_0)) \leq (C_0/\alpha_0^2)\varepsilon^2 \mathcal{A}(S(\xi, h))$; and, on the other hand, for $\alpha_0 \leq \varepsilon \leq 1$, $\mathcal{A}(S(\xi, \varepsilon h)) \leq \mathcal{A}(S(\xi, h)) \leq (1/\alpha_0^2)\varepsilon^2 \mathcal{A}(S(\xi, h))$.

Since, moreover, it suffices to make the proof for $\xi = 1$, Theorem 3.1 will result from the following theorem.

Theorem 3.3 There exist a constant $K > 0$, $\alpha_0 > 0$ and $\lambda_0 > 1$ such that every analytic function $f: \mathbb{D} \rightarrow \Pi^+$ with $|f(0)| \leq \alpha_0$ satisfies, for every $\lambda \geq \lambda_0$:

$$\mathcal{A}(\{|f| > \lambda\}) \leq \frac{K}{\lambda^2} \mathcal{A}(\{|f| > 1\}),$$

where Π^+ is the right-half plane $\Pi^+ = \{z \in \mathbb{C}; \Re z > 0\}$.

Indeed, let $f = h/(1-\varphi)$. Then $\Re f > 0$ and $|f(0)| \leq h/(1-|\varphi(0)|) \leq \alpha_0$. We may apply Theorem 3.3 and we get, for $0 < \varepsilon \leq 1/\lambda_0$:

$$\begin{aligned} \mathcal{A}_\varphi(S(1, \varepsilon h)) &= \mathcal{A}(\{|\varphi - 1| < \varepsilon h\}) = \mathcal{A}(\{|f| > 1/\varepsilon\}) \\ &\leq K\varepsilon^2 \mathcal{A}(\{|f| > 1\}) = K\varepsilon^2 \mathcal{A}(\{|1 - \varphi| < h\}) = K\varepsilon^2 \mathcal{A}_\varphi(S(1, h)), \end{aligned}$$

which proves Theorem 3.1. \square

3.1.1 Some lemmas

Lemma 3.4 There is some constant $C_1 > 0$ such that

$$(3.3) \quad \mathcal{A}(\{|f| > \lambda\}) \leq \frac{C_1}{\lambda^2} |f(0)|^2,$$

for every analytic function $f: \mathbb{D} \rightarrow \Pi^+$ and for every $\lambda > 0$.

In particular, there is a constant $K_1 > 0$ such that $\|f\|_{L^1(\mathbb{D})} \leq K_1 |f(0)|^2$ for every such a function.

Proof. We may assume that $|f(0)| = 1$.

The second assertion follows from the first one:

$$\int_{\mathbb{D}} |f| d\mathcal{A} = \int_0^{+\infty} \mathcal{A}(\{|f| > \lambda\}) d\lambda \leq \int_0^1 d\lambda + \int_1^{+\infty} \frac{C_1}{\lambda^2} d\lambda = 1 + C_1 := K_1;$$

To prove the first assertion, remark first that the left-hand side of inequality (3.3) is ≤ 1 , so (3.3) is obvious for $\lambda \leq 2$ (with $C_1 \geq 4$). Assume that $\lambda > 2$, and set $\varphi(z) = \frac{f(z)-f(0)}{f(z)+f(0)}$. Then $|f(z)| > \lambda$ implies $|\varphi(z) - 1| = 2|\Re f(0)|/|f(z) + \overline{f(0)}| \leq 2/(\lambda - 1) \leq 4/\lambda$. But φ maps \mathbb{D} into itself and hence induces a bounded composition operator $C_\varphi: \mathfrak{B}^2 \rightarrow \mathfrak{B}^2$. It follows from [4] that \mathcal{A}_φ is a Bergman-Carleson measure, and hence (see the proof of Theorem 2.1, 1), with $\Psi_1(x) = \Psi_2(x) = x^2$):

$$\begin{aligned} \mathcal{A}(\{|f| > \lambda\}) &\leq \mathcal{A}_\varphi(S(1, 4/\lambda)) \leq \mathcal{A}_\varphi(W(1, 12/\lambda)) \\ &\leq C_0 \|C_\varphi\|^2 / (\lambda/12)^2 = C'_0 \|C_\varphi\|^2 / \lambda^2, \end{aligned}$$

for some constant $C_0 \leq 2500^2/4$. But $\|C_\varphi\| \leq \frac{1+|\varphi(0)|}{1-|\varphi(0)|} = 1$ ([14], Theorem 11.6, page 308), and the result follows. \square

Let:

$$(3.4) \quad G = \{z \in \mathbb{C}; |\arg z| < \pi/4\}.$$

By applying Lemma 3.4 to f^2 , we get, where :

Lemma 3.5 *There exists a constant $C_2 > 0$ such that every analytic function $f: \mathbb{D} \rightarrow G$, one has, for every $\lambda > 0$*

$$(3.5) \quad \mathcal{A}(\{|f| > \lambda\}) \leq \frac{C_2}{\lambda^4} |f(0)|^4.$$

In particular there is a constant $K_2 > 0$ such that $\|f\|_{L^2(\mathbb{D})} \leq K_2 |f(0)|^4$ for every such a function.

Now, we shall have to replace \mathbb{D} by some conformal copies of \mathbb{D} . This will be possible by the following version of Lemma 3.5.

Lemma 3.6 *Let Ω be a bounded Jordan domain bounded by a \mathcal{C}^1 Jordan curve J and let $c \in \Omega$. Let $\Delta = T(\Omega)$ be a domain similar to Ω , i.e. $T(z) = \alpha z + \beta$ with $\alpha \neq 0$. Set $\gamma = T(c)$. Then, there exists a constant $C > 0$, depending only on Ω and c , such that, for any $\lambda > 0$ and any analytic function $f: \Delta \rightarrow G$, one has:*

$$(3.6) \quad \mathcal{A}(\{|f| > \lambda\}) \leq \frac{C}{\lambda^4} |f(\gamma)|^4 \mathcal{A}(\Omega).$$

In particular, there is a constant $K = K(\Omega, c) > 0$ such that $\|f\|_2 \leq K |f(\gamma)|^4 \mathcal{A}(\Omega)$ for all such functions.

Moreover $C > 0$ can be taken so that, for every positive harmonic function $u: \Delta \rightarrow \mathbb{R}_+$, one has:

$$(3.7) \quad \frac{1}{C} u(\gamma) \leq \frac{1}{\mathcal{A}(\Delta)} \int_{\Delta} u d\mathcal{A} \leq C u(\gamma).$$

Proof. First take a Riemann map $h: \mathbb{D} \rightarrow \Omega$ such that $h(0) = c$, which extends to a bi-Lipschitz homeomorphism h of $\overline{\mathbb{D}}$ to $\overline{\Omega}$. Hence, for some constants $a, b > 0$, we have:

$$a \leq |h'(z)| \leq b, \quad \forall z \in D.$$

Then, by the change-of-variable formula, we have, setting $F = f \circ h$ and $w = h(z)$:

$$\begin{aligned} \mathcal{A}(\{|f| > \lambda\}) &= \int_{\Omega} \mathbb{1}_{\{|f| > \lambda\}}(w) d\mathcal{A}(w) = \int_{\mathbb{D}} \mathbb{1}_{\{|F| > \lambda\}}(z) |h'(z)|^2 d\mathcal{A}(z) \\ &\leq b^2 \int_{\mathbb{D}} \mathbb{1}_{\{|F| > \lambda\}}(z) d\mathcal{A}(z) = b^2 \mathcal{A}(\{|F| > \lambda\}) \leq b^2 \frac{C_2}{\lambda^4}. \end{aligned}$$

We implicitly used the fact that F maps \mathbb{D} to G and that $|F(0)| = |f(c)| \leq 1$, so we are allowed to use the previous lemma. Moreover, we have

$$\mathcal{A}(\Omega) = \int_{\Omega} d\mathcal{A}(w) = \int_{\mathbb{D}} |h'(z)|^2 d\mathcal{A}(z) \geq a^2 \mathcal{A}(\mathbb{D}) = a^2;$$

so that finally:

$$\mathcal{A}(\{|f| > \lambda\}) \leq C_2 \frac{b^2}{a^2} \frac{1}{\lambda^4} \mathcal{A}(\Omega) \stackrel{def}{=} \frac{C}{\lambda^4} \mathcal{A}(\Omega).$$

This ends the proof of the first part of Lemma 3.6 for Ω , with $C = C_2 b^2 / a^2$, since the case of similar domains is a trivial consequence: if $\Delta = T(\Omega)$ is such a domain and $\gamma = T(c)$, let $h_1 = T \circ h$. We have $|h'| = |\alpha| |h'| \leq |\alpha| b$, as well as $|h'| \geq |\alpha| a$, so that a and b are respectively changed into $a' = |\alpha| a$ and $b' = |\alpha| b$, and the quotient $b/a = b'/a'$ remaining unchanged. Moreover, $h_1(\mathbb{D}) = \Delta$ and $h_1(0) = T(c) = \gamma$, so the previous case gives the result.

Finally, one has:

$$\begin{aligned} u(\gamma) &= (u \circ h_1)(0) = \int_{\mathbb{D}} (u \circ h_1)(z) d\mathcal{A}(z) \\ &\geq \frac{1}{b'^2} \int_{\mathbb{D}} u(h_1(z)) d\mathcal{A}(z) = \frac{1}{b'^2} \int_{\Delta} u(w) d\mathcal{A}(w), \end{aligned}$$

which gives the right-hand side of (3.7), since $\mathcal{A}(\Delta) \geq a'^2$. The left-hand side is proved in the same way. \square

The last lemma is of a different kind.

Lemma 3.7 *For every analytic function $f: D(z_0, r) \rightarrow G$, one has:*

$$\mathcal{A}(\{\Re f > \Re f(z_0)/2\}) \geq \frac{1}{8K_2^2} \mathcal{A}(D(z_0, r)),$$

where K_2 is the constant given by Lemma 3.5.

Proof. Recall Paley-Zygmund's inequality (see [9], Proposition III.3), usually stated in probabilistic language: for any positive random variable X on some probability space, one has, for $0 < a < 1$:

$$(3.8) \quad \mathbb{P}(X > a \mathbb{E}(X)) \geq (1 - a)^2 \frac{[\mathbb{E}(X)]^2}{\mathbb{E}(X^2)},$$

where \mathbb{E} stands for expectation.

For our problem, we will take as probability space the disk $D(z_0, r)$ equipped with the probability measure $d\mathcal{A}/r^2$, and as random variable $X = \Re f := u$. We get from (3.8) that, since $u(z_0) = \mathbb{E}(X)$ by the mean value property of harmonic functions:

$$\mathcal{A}(\{u > a u(z_0)\}) \geq (1 - a)^2 \frac{[u(z_0)]^2}{\mathbb{E}(u^2)} r^2.$$

Now, observe that $\sqrt{2} \Re w \geq |w|$ when $w \in G$; hence the function $g(z) = f(z - z_0)/[\sqrt{2}u(z_0)]$, which maps \mathbb{D} into G , satisfies $|g(0)| \leq 1$ and Lemma 3.5 gives $\mathbb{E}(u^2) \leq \mathbb{E}(|f|^2) = \|f\|_2^2 \leq 2K_2^2[u(z_0)]^2$. We get:

$$\mathcal{A}(\{u > a u(z_0)\}) \geq \frac{(1 - a)^2}{2K_2^2} r^2,$$

which gives the desired result in taking $a = 1/2$. □

3.1.2 Proof of Theorem 3.3.

For technical reason, we are going to work with functions with range in the set G . Proving Theorem 3.3 amounts to prove:

Proposition 3.8 *There exist a constant $K' > 0$, $\alpha_1 > 0$ and $\lambda_1 > 1$ such that every analytic function $f : \mathbb{D} \rightarrow G$ with $|f(0)| \leq \alpha_1$ satisfies, for $\lambda \geq \lambda_1$:*

$$\mathcal{A}(\{|f| > \lambda\}) \leq \frac{K'}{\lambda^4} \mathcal{A}(\{|f| > 1\}).$$

It will be useful to note that $\sqrt{2}w \geq |w|$ when $w \in G$.

Proof. The idea of the proof is to split $F_\lambda = \{|f| > \lambda\}$ (actually, F_λ will be conditioned by the more regular set $\{M_d f > 1\}$) in parts on which we shall be able to apply Lemma 3.6. In order to construct these parts, we shall use a Calderón-Zygmund type decomposition adapted to the geometry of the unit disk. We are going to recall the principle of this decomposition for the convenience of the reader.

Before that, we have to say that we shall begin to work not with the function f as is the statement of Proposition 3.8, but with this function multiplied by a constant (as we shall precise at the end of the proof). Nevertheless, we shall call this new function by f yet.

Now, remark that for $f: \mathbb{D} \rightarrow G$ with $|f(0)| \leq \alpha < 1$, one has:

$$(3.9) \quad |f(z)| > 1 \implies |z| > \beta,$$

for $\beta = (1 - \alpha^2)/(1 + \alpha^2)$. In fact, setting $a = f(0)$, the function $g = \frac{f^2 - a^2}{f^2 + a^2}$ maps \mathbb{D} into itself and vanishes at 0. By Schwarz's lemma, $|z| \leq \beta$ implies $|g(z)| \leq \beta$, and since $f^2 = \frac{\bar{a}^2 g + a^2}{1 - g}$, we get:

$$|f(z)|^2 \leq \frac{|a|^2 \beta + |a|^2}{1 - \beta} = \frac{|a|^2}{\alpha^2} \leq 1.$$

The goal of the remark (3.9) is that, in order to make the Calderón-Zygmund decomposition, we have to avoid the center 0 of \mathbb{D} , which is not covered by the dyadic "squares" defined below.

Recall now the Calderón-Zygmund decomposition. We consider the family $\mathcal{S} = \bigcup_{n \in \mathbb{N}} \mathcal{S}_n$ of all dyadic half-open "squares", where \mathcal{S}_n is the family of sets

$$S = \{z \in \mathbb{D}; r_1 \leq |z| < r_2 \text{ and } 2\pi\theta_1 \leq \arg z < 2\pi\theta_2\},$$

where $r_1 = 1 - 2^{-n}(j+1)$, $r_2 = 1 - 2^{-n}j$, $\theta_1 = 2^{-n}k$, $\theta_2 = 2^{-n}(k+1)$, $0 \leq j, k \leq 2^n - 1$ are pairs of "consecutive" dyadic numbers in $(0, 1)$.

Consider the conditional expectation $\mathbb{E}_n|f|$ of $|f|$, given the sigma-algebra generated by \mathcal{S}_n , namely:

$$(\mathbb{E}_n|f|)(z) = \sum_{S \in \mathcal{S}_n} \left(\frac{1}{\mathcal{A}(S)} \int_S |f| d\mathcal{A} \right) \mathbb{1}_S(z).$$

The dyadic maximal function $M_d f$ is defined by:

$$M_d f(z) = \sup_n (\mathbb{E}_n|f|)(z).$$

Note that:

$$M_d f(z) = \sup_{S_z} \frac{1}{\mathcal{A}(S_z)} \int_{S_z} |f| d\mathcal{A},$$

where the supremum is taken over all $S_z \in \mathcal{S}$ containing z .

By Lebesgue's differentiation Theorem (or by the martingale convergence Theorem), we know that $(\mathbb{E}_n|f|)(z)$ converges to $|f(z)|$, \mathcal{A} -almost everywhere, so $M_d f(z) \leq 1$ implies $|f(z)| \leq 1$ for almost all $z \in \mathbb{D}$, and we can write:

$$(3.10) \quad F_1 = \{|f| > 1\} \subseteq \{M_d f > 1\} \cup N,$$

where N is a negligible set. Hence $F_\lambda \subseteq \{M_d f > 1\} \cup N$ for $\lambda \geq 1$. Now, the set $\{M_d f > 1\}$ can be decomposed in a disjoint union $\{M_d f > 1\} = \bigsqcup_n E_n$, where

$$E_n = \{z \in \mathbb{D}; (\mathbb{E}_n|f|)(z) > 1 \text{ and } (\mathbb{E}_j|f|)(z) \leq 1 \text{ if } j < n\}.$$

Since $\mathbb{E}_n|f|$ is constant on the squares $S \in \mathcal{S}_n$, each E_n can be in its turn decomposed into a disjoint union $E_n = \bigsqcup_k S_{n,k}$, where $S_{n,k} \in \mathcal{S}_n$.

By definition, for $z \in E_n$, one has $(\mathbb{E}_n |f|)(z) \geq 1$ and hence

$$\frac{1}{\mathcal{A}(S_{n,k})} \int_{S_{n,k}} |f| d\mathcal{A} \geq 1 \quad \text{for } z \in S_{n,k}.$$

But, on the other hand, $(\mathbb{E}_{n-1} |f|)(z) \leq 1$, and, since the area of an $(n-1)$ -dyadic square is four times that of an n -dyadic one, we have, if $z \in S_{n,k}$:

$$\begin{aligned} (\mathbb{E}_n |f|)(z) &= \frac{1}{\mathcal{A}(S_{n,k})} \int_{S_{n,k}} |f| d\mathcal{A} \\ &\leq \frac{1}{\mathcal{A}(S_{n,k})} \int_{S_{n-1,j}} |f| d\mathcal{A} = 4 \frac{1}{\mathcal{A}(S_{n-1,j})} \int_{S_{n-1,j}} |f| d\mathcal{A} \leq 4, \end{aligned}$$

where $S_{n-1,j}$ is the dyadic square of rank $(n-1)$ containing $S_{n,k}$.

Finally, reindexing the sets $S_{k,n}$, we can write $\{M_d f > 1\}$ as a disjoint union

$$(3.11) \quad \{M_d f > 1\} = \bigsqcup_{l \geq 1} S_l,$$

for which:

$$(3.12) \quad 1 \leq \frac{1}{\mathcal{A}(S_l)} \int_{S_l} |f| d\mathcal{A} \leq 4,$$

Equations (3.10), (3.11) and (3.12) define the Calderón-Zygmund decomposition of the function f .

In order to apply Lemma 3.6, we have to control (from above and *from below*) the values of $|f|$ at the “center” of the squares. One might think of doing this by using (3.12), but it is not always possible (for example, the function $1/z^2$ is not integrable on the square of vertices $0, 1+i, 1-i, 2$). Nevertheless, we may enlarge these squares in order to use (3.12).

Let us round the sets S_l in \hat{S}_l , by adding half-disks, as indicated in *Figure 1*. Those sets \hat{S}_l can be performed by making similarities from

$$S_{0,1} = \{z \in \mathbb{D}; 1/2 \leq |z| < 1 \text{ and } 0 \leq \arg z < \pi/2\}.$$

Moreover, the boundary of each \hat{S}_l is \mathcal{C}^1 , hence conformally and bi-Lipschitz equivalent to \mathbb{D} ; therefore, we are able to apply Lemma 3.6 with, as it is essential, a constant independent of the index l : for some constant $C > 0$, one has, for every $l \geq 1$, if γ_l is the center (defined in an obvious way) of S_l (and hence of \hat{S}_l):

$$\mathcal{A}(\{z \in \hat{S}_l; |f(z)| > \lambda\}) \leq \frac{C}{\lambda^4} |f(\gamma_l)|^4 \mathcal{A}(\hat{S}_l).$$

Now, let D_l be the greatest open disk with center γ_l and contained in S_l (see *Figure 2*). We have, by the last part of Lemma 3.6:

$$|f(\gamma_l)| \leq \frac{C}{\mathcal{A}(D_l)} \int_{D_l} |f| d\mathcal{A} \leq \frac{16C}{\mathcal{A}(S_l)} \int_{S_l} |f| d\mathcal{A} \leq 64C.$$

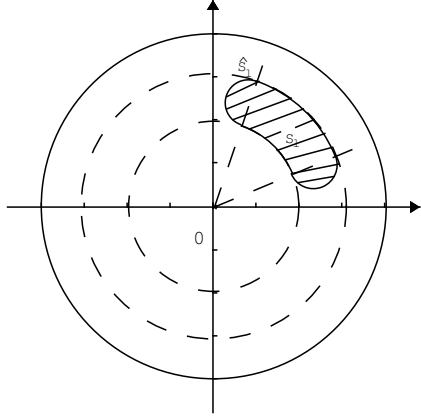

Figure 1: Round dyadic set \hat{S}_l

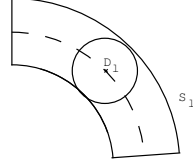

Figure 2: Disk D_l

Using the fact that $\mathcal{A}(\hat{S}_l) \leq 4\mathcal{A}(S_l)$ and that $F_\lambda \subseteq \{M_{df} > 1\} \cup N$ when $\lambda \geq 1$, we get:

$$\begin{aligned}
 (3.13) \quad \mathcal{A}(F_\lambda) &= \mathcal{A}(F_\lambda \cap \{M_{df} > 1\}) \leq \sum_{l \geq 1} \mathcal{A}(\{z \in \hat{S}_l; |f(z)| > \lambda\}) \\
 &\leq \frac{C}{\lambda^4} (64C)^4 \sum_{l \geq 1} \mathcal{A}(\hat{S}_l) \leq \frac{2^{26} C^5}{\lambda^4} \sum_{l \geq 1} \mathcal{A}(S_l) \\
 &= \frac{2^{26} C^5}{\lambda^4} \mathcal{A}(\{M_{df} > 1\}).
 \end{aligned}$$

It remains to control $\mathcal{A}(\{M_{df} > 1\})$ by $\mathcal{A}(\{|f| > \delta\})$, for some numerical $\delta > 0$.

For that, we shall use Lemma 3.7. By harmonicity and Lemma 3.6, one has, with $u = \Re f$:

$$\begin{aligned}
 u(\gamma_l) &\geq \frac{1/C}{\mathcal{A}(\hat{S}_l)} \int_{\hat{S}_l} u \, d\mathcal{A} \geq \frac{1}{4C} \frac{1}{\mathcal{A}(S_l)} \int_{S_l} u \, d\mathcal{A} \\
 &\geq \frac{1}{4\sqrt{2}C} \frac{1}{\mathcal{A}(S_l)} \int_{S_l} |f| \, d\mathcal{A} \geq \frac{1}{4\sqrt{2}C}.
 \end{aligned}$$

We now apply Lemma 3.7 and we get:

$$\begin{aligned}
 \mathcal{A}(\{|f| > 1/8C\}) &\geq \mathcal{A}(\{u > 1/4\sqrt{2}C\}) \geq \mathcal{A}(\{u > u(\gamma_l)/2\}) \\
 &\geq \frac{1}{8K_2^2} \mathcal{A}(D_l).
 \end{aligned}$$

We obtain hence:

$$(3.14) \quad \mathcal{A}(\{M_{df} > 1\}) = \sum_{l \geq 1} \mathcal{A}(S_l) \leq 4 \sum_{l \geq 1} \mathcal{A}(D_l) \leq 32K_2^2 \mathcal{A}(\{|f| > 1/8C\}).$$

The proof of Theorem 3.3 is now finished, because (3.13) and (3.14) give, for $\lambda \geq 1$:

$$(3.15) \quad \mathcal{A}(\{|f| > \lambda\}) \leq \frac{2^{31} C^5 K_2^2}{\lambda^4} \mathcal{A}(\{|f| > 1/8C\})$$

and if f is as in the statement of Proposition 3.8, we can apply (3.15) to $f_1 = f/8C$ and we get, for $\lambda \geq \lambda_1 = 8C$:

$$\mathcal{A}(\{|f| > \lambda\}) \leq \frac{2^{31} (8C)^4 C^5 K_2^2}{\lambda^4} \mathcal{A}(\{|f| > 1\}),$$

when $|f(0)| \leq 8C$. □

3.2 Nevanlinna counting function

Nevanlinna counting function is defined, for every analytic function $\varphi: \mathbb{D} \rightarrow \mathbb{D}$, and for every $w \in \varphi(\mathbb{D}) \setminus \{\varphi(0)\}$, by:

$$(3.16) \quad N_\varphi(w) = \sum_{\varphi(z)=w} \log \frac{1}{|z|},$$

where each term $\log \frac{1}{|z|}$ being repeated according to the multiplicity of z , and by $N_\varphi(w) = 0$ for the other $w \in \mathbb{D}$.

Recall (see [8] that, if m is the normalized Lebesgue measure on \mathbb{T} , then the Carleson function of φ is the Carleson function of the pull-back measure m_φ of m by φ . We proved in [8] (Theorem 3.1 and Theorem 3.7) that it is equivalent to the Carleson function ρ_φ in the following way.

Theorem 3.9 ([8]) *There exist two universal constants $C, c > 1$, such that, for every analytic self-map $\varphi: \mathbb{D} \rightarrow \mathbb{D}$, one has:*

$$(3.17) \quad \sup_{w \in W(\xi, h) \cap \mathbb{D}} N_\varphi(w) \leq C m_\varphi[W(\xi, ch)],$$

and

$$(3.18) \quad m_\varphi(W(\xi, h)) \leq C \frac{1}{\mathcal{A}(W(\xi, ch))} \int_{W(\xi, ch)} N_\varphi(z) d\mathcal{A}(z)$$

for $0 < h < 1$ small enough.

We are going to deduce from Theorem 3.9 the same result in the 2-dimensional case. The Nevanlinna counting function of order 2 is defined (see [12], § 6.2), for $w \in \mathbb{D} \setminus \{\varphi(0)\}$, by:

$$(3.19) \quad N_{\varphi,2}(w) = \sum_{\varphi(z)=w} (\log(1/|z|))^2,$$

where each preimage z of w appears as often as its multiplicity. The partial Nevanlinna counting function is defined, for $0 < r \leq 1$ by:

$$N_\varphi(r, w) = \sum_{\varphi(z)=w, |z|<r} \log(1/|z|)$$

and we have ([12], Proposition 6.6, where a misprint occurs):

$$(3.20) \quad N_{\varphi,2}(w) = 2 \int_0^1 N_\varphi(r, w) \frac{dr}{r}.$$

One has:

Theorem 3.10 *There exists a universal constant $C > 1$, such that, for every analytic self-map $\varphi: \mathbb{D} \rightarrow \mathbb{D}$, one has:*

$$(3.21) \quad (1/C) \rho_{\varphi,2}(h/C) \leq \sup_{|w| \geq 1-h} N_{\varphi,2}(w) \leq C \rho_{\varphi,2}(Ch),$$

for $0 < h < 1$ small enough.

Proof. Let $w_0 = \varphi(0)$ and set:

$$u(z) = \frac{w_0 - \varphi(z)}{1 - \overline{w_0} \varphi(z)}.$$

Since $u(0) = 0$, Schwarz's lemma gives $|u(z)| \leq |z|$. Hence there is no z with $|z| < t$ such that $\varphi(z) = w$ when $t \leq |w_0 - w|/|1 - \overline{w_0} w| = |u(w)|$. It follows that (3.20) actually writes:

$$(3.22) \quad N_{\varphi,2}(w) = 2 \int_{|u(w)|}^1 N_\varphi(r, w) \frac{dr}{r}.$$

1) It follows from (3.22) that:

$$N_{\varphi,2}(w) \leq \frac{2}{|u(w)|^2} \int_0^1 N_\varphi(r, w) r \, dr.$$

But (see [8], Lemma 3.4) $1/|u(w)| = |w - w_0|/|1 - \overline{w_0} w| > 1/3$ when $1 - |w| < (1 - |w_0|)/4$; therefore, for $1 - |w| < (1 - |w_0|)/4$, we have:

$$N_{\varphi,2}(w) \leq 18 \int_0^1 N_\varphi(r, w) r \, dr.$$

Now, $N_\varphi(r, w) = N_{\varphi_r}(w)$, where $\varphi_r(z) = \varphi(rz)$, and it follows from (3.17) that, for $w \in W(\xi, h)$, with $\xi \in \mathbb{T}$ and $h > 0$ small enough, one has:

$$\begin{aligned} N_{\varphi,2}(w) &\leq 18 \int_0^1 C m_{\varphi_r}[W(\xi, ch)] r \, dr \\ &= 18C \int_0^1 m(\{e^{i\theta}; \varphi(re^{i\theta}) \in W(\xi, ch)\}) r \, dr \\ &= 9CA(\{z \in \mathbb{D}; \varphi(z) \in W(\xi, ch)\}). \end{aligned}$$

2) Conversely, it follows from (3.20) that:

$$N_{\varphi,2}(w) \geq 2 \int_0^1 N_{\varphi}(r, w) r dr;$$

hence:

$$\begin{aligned} & \frac{1}{\mathcal{A}[W(\xi, ch)]} \int_{W(\xi, ch)} N_{\varphi,2}(z) d\mathcal{A}(z) \\ & \geq 2 \int_0^1 \left[\frac{1}{\mathcal{A}[W(\xi, ch)]} \int_{W(\xi, ch)} N_{\varphi}(r, z) d\mathcal{A}(z) \right] r dr \\ & \geq \frac{2}{C} \int_0^1 m_{\varphi_r}[W(\xi, h)] r dr \\ & = \frac{2}{C} \int_0^1 m(\{e^{i\theta}; \varphi(re^{i\theta}) \in W(\xi, h)\}) r dr \\ & = \frac{1}{C} \mathcal{A}(\{z \in \mathbb{D}; \varphi(z) \in W(\xi, h)\}), \end{aligned}$$

and that finishes the proof of Theorem 3.10. □

Remark. Actually, the proof shows that for some constant $C > 1$, one has:

$$(3.23) \quad (1/C) \mathcal{A}_{\varphi}[W(\xi, h/C)] \leq \sup_{w \in W(\xi, h)} N_{\varphi,2}(w) \leq C \mathcal{A}_{\varphi}[W(\xi, Ch)],$$

for every $\xi \in \mathbb{T}$ and $0 < h < 1$ small enough. Since, by Cauchy-Schwarz's inequality, one has $N_{\varphi,2}(w) \leq [N_{\varphi}(w)]^2$, it follows hence from Theorem 3.9 and Theorem 3.10 (actually (3.23)) that, for some constant $C > 1$, one has:

$$(3.24) \quad \mathcal{A}(\{z \in \mathbb{D}; \varphi(z) \in W(\xi, h)\}) \leq C [m(\{u \in \mathbb{T}; \varphi^*(u) \in W(\xi, Ch)\})]^2,$$

for every $\xi \in \mathbb{T}$ and every $0 < h < 1$ small enough, a fact which does not seem to be proved in a straightforward way.

Corollary 3.11 *For every analytic self-map $\varphi: \mathbb{D} \rightarrow \mathbb{D}$ and for every Orlicz function Ψ , the composition operator $C_{\varphi}: \mathfrak{B}^{\Psi} \rightarrow \mathfrak{B}^{\Psi}$ is compact if and only if:*

$$(3.25) \quad \lim_{h \rightarrow 0} \frac{\Psi^{-1}(1/h^2)}{\Psi^{-1}(1/\nu_{\varphi,2}(h))} = 0,$$

where $\nu_{\varphi,2}(h) = \sup_{|w| \geq 1-h} N_{\varphi,2}(w)$.

Proof. If C_{φ} is compact, Theorem 3.2 gives, for every $A > 0$, an $h_A > 0$ such that, for $0 < h \leq h_A$:

$$\Psi^{-1}(1/h^2) \leq \frac{1}{A} \Psi^{-1}(1/\rho_{\varphi,2}(h)).$$

Then Theorem 3.10 gives:

$$\nu_{\varphi,2}(h) \leq C \rho_{\varphi,2}(Ch) \leq C/\Psi[A\Psi^{-1}(1/C^2h^2)],$$

i.e. $A\Psi^{-1}(1/C^2h^2) \leq \Psi^{-1}[C/\nu_{\varphi,2}(h)]$; and then, by concavity, since $C > 1$:

$$\frac{1}{C^2} \Psi^{-1}(1/h^2) \leq \Psi^{-1}(1/C^2h^2) \leq \frac{1}{A} \Psi^{-1}(C/\nu_{\varphi,2}(h)) \leq \frac{C}{A} \Psi^{-1}(1/\nu_{\varphi,2}(h)),$$

which implies (3.25).

The converse follows the same lines. □

Corollary 3.12 *The compactness of the composition operator $C_{\varphi}: \mathfrak{B}^{\Psi} \rightarrow \mathfrak{B}^{\Psi}$ implies that:*

$$\lim_{|z| \rightarrow 1} \frac{\Psi^{-1}(1/[1 - |\varphi(z)|]^2)}{\Psi^{-1}((1 - |z|)^2)} = 0.$$

This corollary was proved in [7], Theorem 5.7, by a more direct method; and we also showed that the condition is sufficient when Ψ grows enough (namely, satisfies the condition Δ^2).

Proof. Since $N_{\varphi,2}(\varphi(z)) \geq (\log(1/|z|))^2 \geq (1 - |z|)^2$, it follows from Corollary 3.11 that, for every $A > 0$, one has:

$$(1 - |z|)^2 \leq \frac{1}{\Psi[A\Psi^{-1}(1/(1 - |\varphi(z)|)^2)]};$$

that is:

$$\frac{\Psi^{-1}(1/(1 - |\varphi(z)|)^2)}{\Psi^{-1}((1 - |z|)^2)} \leq 1/A,$$

and that proves Corollary 3.12. □

4 Comparison of the compactness of composition operators on Hardy-Orlicz spaces and on Bergman-Orlicz spaces

In the classical case ($\Psi(x) = x^p$, $1 \leq p < \infty$), it is known ([10], Theorem 3.5, with Proposition 2.7) that the compactness of $C_{\varphi}: H^p \rightarrow H^p$ implies the compactness of $C_{\varphi}: \mathfrak{B}^p \rightarrow \mathfrak{B}^p$. On the other hand, we implicitly proved in [7], Theorem 5.7, that when Ψ grows very fast (namely, satisfies the so-called Δ^2 condition), then the compactness of $C_{\varphi}: H^{\Psi} \rightarrow H^{\Psi}$ implies the compactness of $C_{\varphi}: \mathfrak{B}^{\Psi} \rightarrow \mathfrak{B}^{\Psi}$. Let us write why: it is easy to show (see [8], proof of Theorem 4.3) that the compactness of $C_{\varphi}: H^{\Psi} \rightarrow H^{\Psi}$ implies that $\Psi^{-1}[1/1 - |\varphi(z)|]/\Psi^{-1}[1/(1 - |z|)]$ tends to 0 as $|z|$ goes to 1, and we actually proved in [7], Theorem 5.7, that, when $\Psi \in \Delta^2$, this last condition implies the compactness of $C_{\varphi}: \mathfrak{B}^{\Psi} \rightarrow \mathfrak{B}^{\Psi}$. The next proposition gives a condition, though not very satisfactory, on Ψ which includes the cases $\Psi(x) = x^p$ and $\Psi \in \Delta^2$ and for which the compactness on H^{Ψ} implies the compactness on \mathfrak{B}^{Ψ} .

Proposition 4.1 *Assume that the Orlicz function Ψ satisfies the following condition: for every $A > 0$, there exist $x_A > 0$ and $B \geq A$ such that:*

$$(4.1) \quad \Psi[A\Psi^{-1}(x^2)] \leq (\Psi[B\Psi^{-1}(x)])^2$$

for every $x \geq x_A$. Then every analytic map $\varphi: \mathbb{D} \rightarrow \mathbb{D}$ defining a compact composition operator $C_\varphi: H^\Psi \rightarrow H^\Psi$ also defines compact composition operator $C_\varphi: \mathfrak{B}^\Psi \rightarrow \mathfrak{B}^\Psi$.

It is clear that Ψ satisfies (4.1) if $\Psi(x) = x^p$. Recall that condition Δ^2 means that there exists some $\alpha > 1$ such that $[\Psi(t)]^2 \leq \Psi(\alpha t)$ for t large enough. For such a function, one has $\Psi^{-1}(x^2) \leq \alpha\Psi^{-1}(x)$, and hence $\Psi[A\Psi^{-1}(x^2)] \leq \Psi[\alpha A\Psi^{-1}(x)]$, which is $\leq (\Psi[\alpha A\Psi^{-1}(x)])^2$ for x large enough, since it tends to infinity. Therefore, (4.1) holds if Ψ has Δ^2 . Classical examples of Orlicz functions with Δ^2 are $\Psi(x) = e^{x^q} - 1$, where $q \geq 1$.

Another example, which does not have Δ^2 , but satisfies (4.1), is $\Psi(x) = \exp([\log(x+1)]^2)$.

Proof of Proposition 4.1. One has $N_{\varphi,2}(w) \leq [N_\varphi(w)]^2$ by Cauchy-Schwarz's inequality. Let $A > 0$ be arbitrary. If C_φ is compact on H^Ψ , we know, by [8], Theorem 4.2, that:

$$\sup_{|w| \geq 1-h} N_\varphi(w) = o\left(\frac{1}{\Psi[B\Psi^{-1}(1/h)]}\right), \quad \text{as } h \rightarrow 0.$$

By (4.1), we get:

$$\sup_{|w| \geq 1-h} N_{\varphi,2}(w) = o\left(\frac{1}{\Psi[A\Psi^{-1}(1/h^2)]}\right).$$

Corollary 3.11 ensures that C_φ is compact on \mathfrak{B}^Ψ . □

However, we are going to see that the conclusion of Proposition 4.1 does not hold for an arbitrary Orlicz function, in proving the following theorem.

Theorem 4.2 *There exist an analytic self-map $\varphi: \mathbb{D} \rightarrow \mathbb{D}$ and Orlicz function Ψ such that $C_\varphi: H^\Psi \rightarrow H^\Psi$ is compact whereas $C_\varphi: \mathfrak{B}^\Psi \rightarrow \mathfrak{B}^\Psi$ is not compact.*

In order to prove it, we shall show and use the following result.

Theorem 4.3 *There exists an analytic self-map $\varphi: \mathbb{D} \rightarrow \mathbb{D}$ such that, for some constants $c_2 \geq \pi$ and $\pi/4 \geq c_1 > 0$, one has, for some constant $C > 0$ and for $h > 0$ small enough:*

$$(4.2) \quad \rho_\varphi(h) \leq C e^{-c_1/h};$$

$$(4.3) \quad \rho_{\varphi,2}(h) \geq (1/C) e^{-c_2/h}.$$

We may remark that this result is rather sharp, since, by (3.24), one must have $\rho_{\varphi,2}(h) \leq C [\rho_{\varphi}(h)]^2$ and hence, here, $2c_1 \leq c_2$.

Proof of Theorem 4.2. We know ([7], Theorem 4.18) that $C_{\varphi}: H^{\Psi} \rightarrow H^{\Psi}$ is compact if and only if

$$(4.4) \quad \lim_{h \rightarrow 0} \frac{\Psi^{-1}(1/h)}{\Psi^{-1}(1/\rho_{\varphi}(h))} = 0$$

and (by Theorem 3.2) that the compactness of $C_{\varphi}: \mathfrak{B}^{\Psi} \rightarrow \mathfrak{B}^{\Psi}$ implies that

$$(4.5) \quad \lim_{h \rightarrow 0} \frac{\Psi^{-1}(1/h^2)}{\Psi^{-1}(1/\rho_{\varphi,2}(h))} = 0$$

Hence, it suffices to construct an Orlicz function Ψ such that:

$$(4.6) \quad \lim_{x \rightarrow \infty} \frac{\Psi^{-1}(x)}{\Psi^{-1}(e^{c_1 x})} = 0;$$

and

$$(4.7) \quad \limsup_{x \rightarrow \infty} \frac{\Psi^{-1}(x^2)}{\Psi^{-1}(e^{c_2 x})} > 0.$$

We shall actually construct an increasing concave function $f: [0, \infty) \rightarrow \mathbb{R}_+$ such that $f(0) = 0$ and $f(\infty) = \infty$ which satisfies (4.6) and (4.7) (with f instead of Ψ^{-1}) and we shall then take $\Psi = f^{-1}$.

1) For that, we set $\alpha_0 = 0$ and we define an increasing sequence of positive numbers $\alpha_1 = 1, \alpha_2, \dots$ by:

$$(4.8) \quad \alpha_{n+1} = e^{c_1 \alpha_n}, \quad n \geq 0,$$

and we take f affine on each interval $[\alpha_n, \alpha_{n+1}]$, $n \geq 0$. More precisely, we set

$$(4.9) \quad f(t) = A_n t + B_n, \quad \text{for } \alpha_{n-1} \leq t \leq \alpha_n, \quad n \geq 1,$$

where $A_1 = 1$, $B_1 = 0$, and for $n \geq 1$:

$$(4.10) \quad B_{n+1} - B_n = (A_n - A_{n+1}) \alpha_n.$$

and, for $n \geq 0$:

$$(4.11) \quad \frac{B_{n+1}}{A_{n+1}} = \frac{1}{2} (e^{c_2 \sqrt{\alpha_n}} - 3\alpha_n).$$

Condition (4.10) ensures that f is continuous. It is clear that f is increasing and that $f(\infty) = \infty$.

Now, since $c_2 > \sqrt{6}$, the function u defined by $u(x) = e^{c_2 x} - 3x^2$ is positive and increasing for $x > 0$; hence, if one sets

$$(4.12) \quad \beta_n = (e^{c_2 \sqrt{\alpha_n}} - 3\alpha_n)/2, \quad n \geq 0,$$

$(\beta_n)_n$ is an increasing sequence of positive numbers. But $\beta_n = B_{n+1}/A_{n+1}$; hence (4.10) gives, for $n \geq 1$:

$$A_n = \frac{\alpha_n + 1/\beta_n}{\alpha_n + 1/\beta_{n-1}} A_{n+1}.$$

Since $\beta_n > \beta_{n-1}$, it follows that $A_n > A_{n+1}$, and so the function f is concave.

2) For n large enough, one has $\alpha_n < e^{c_2\sqrt{\alpha_n}} < e^{c_1\alpha_n} = \alpha_{n+1}$; hence, for these n ,

$$\frac{f(\alpha_n)}{f(e^{c_2\sqrt{\alpha_n}})} = \frac{A_{n+1}\alpha_n + B_{n+1}}{A_{n+1}e^{c_2\sqrt{\alpha_n}} + B_{n+1}} = \frac{\alpha_n + \beta_n}{e^{c_2\sqrt{\alpha_n}} + \beta_n} = \frac{1}{3},$$

and it follows that

$$\limsup_{x \rightarrow \infty} \frac{f(x^2)}{f(e^{c_2x})} \geq \frac{1}{3}.$$

Condition (4.7) is satisfied.

3) It remains to check condition (4.6).

For that, we shall fix a number $M > c_2/c_1$ and take n_0 large enough in order that $\alpha_{n-1} < M\sqrt{\alpha_n} < \alpha_n$ for $n \geq n_0$.

Let x_0 be such that $x \geq x_0$ if and only if $\alpha_{n-1} \leq x < \alpha_n$ with $n \geq n_0$. Choose such an x . We have:

$$\alpha_n = e^{c_1\alpha_{n-1}} \leq e^{c_1x} \leq e^{c_1\alpha_n} = \alpha_{n+1}$$

We shall separate two cases. For convenience, we set $\varepsilon_n = 1/\beta_n$.

a) *Case 1:* $\alpha_{n-1} \leq x < M\sqrt{\alpha_n}$. Then:

$$\begin{aligned} \frac{f(x)}{f(e^{c_1x})} &= \frac{A_nx + B_n}{A_{n+1}e^{c_1x} + B_{n+1}} \leq \frac{A_nM\sqrt{\alpha_n} + B_n}{A_{n+1}\alpha_n + B_{n+1}} \\ &= \frac{A_nM\sqrt{\alpha_n} + B_n}{A_n\alpha_n + B_n}, \quad \text{by (4.10)} \\ &= \frac{\varepsilon_{n-1}M\sqrt{\alpha_n} + 1}{\varepsilon_{n-1}\alpha_n + 1} \sim \frac{M}{\sqrt{\alpha_n}}, \end{aligned}$$

since

$$\varepsilon_{n-1}\sqrt{\alpha_n} = 2 \frac{e^{c_1\alpha_{n-1}/2}}{e^{c_2\sqrt{\alpha_{n-1}}} - 3\alpha_{n-1}} \sim 2 \exp\left(\frac{c_1}{2}\alpha_{n-1} - c_2\sqrt{\alpha_{n-1}}\right) \xrightarrow{n \rightarrow \infty} +\infty.$$

b) *Case 2:* $M\sqrt{\alpha_n} \leq x < \alpha_n$. Then:

$$\begin{aligned} \frac{f(x)}{f(e^{c_1x})} &\leq \frac{f(\alpha_n)}{f(e^{c_1M\sqrt{\alpha_n}})} = \frac{A_{n+1}\alpha_n + B_{n+1}}{A_{n+1}e^{c_1M\sqrt{\alpha_n}} + B_{n+1}} = \frac{\varepsilon_n\alpha_n + 1}{\varepsilon_n e^{c_1M\sqrt{\alpha_n}} + 1} \\ &= \frac{\frac{2\alpha_n}{e^{c_2\sqrt{\alpha_n}} - 3\alpha_n} + 1}{\frac{2e^{c_1M\sqrt{\alpha_n}}}{e^{c_2\sqrt{\alpha_n}} - 3\alpha_n} + 1} \sim \exp\left((c_2 - Mc_1)\sqrt{\alpha_n}\right) \xrightarrow{n \rightarrow \infty} 0 \end{aligned}$$

since $Mc_1 > c_2$.

Putting the two cases together, we get that $\lim_{x \rightarrow +\infty} \frac{f(x)}{f(e^{c_1 x})} = 0$, so (4.6) is satisfied, and Theorem 4.2 is fully proved. \square

Proof of Theorem 4.3. The analytic map φ will be a conformal mapping from \mathbb{D} to the domain G , edged by three arcs of circle of radii $1/2$, and which is represented in *Figure 3*.

More precisely, let $G_0 = \mathbb{D} \cap \{\Re z > 0\}$ and let $f: \mathbb{D} \rightarrow G_0$ be the conformal map such that

$$f(-1) = 0; \quad f(1) = 1; \quad f(i) = i; \quad f(-i) = -i.$$

We define successively $\varphi_1(z) = \log f(z)$, which maps \mathbb{D} onto the half-band $\{\Re w < 0 \mid \Im w < \pi/2\}$, $\varphi_2(z) = -\frac{2}{\pi}\varphi_1(z) + 1$, $\varphi_3(z) = \frac{1}{\varphi_2(z)}$, and finally $\varphi(z) = \varphi_3(z) - 1$.

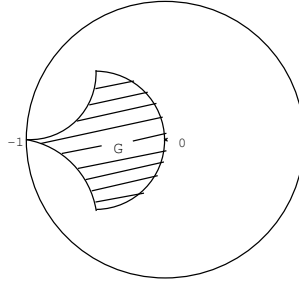

Figure 3: Domain G

1) When $W(\xi, h) \cap G \neq \emptyset$, we must have $W(\xi, h) \cap G \subseteq S(-1, 2h)$, for h small enough. Hence:

$$\begin{aligned} \rho_\varphi(h) &\leq m(\{z \in \mathbb{T}; |\varphi_3(z)| < 2h\}) = m(\{z \in \mathbb{T}; |\varphi_2(z)| > 1/2h\}) \\ &\leq m(\{z \in \mathbb{T}; \Re \varphi_2(z) > 1/2h - 1\}), \quad \text{since } |\Im \varphi_2(z)| < 1, \\ &= m(\{z \in \mathbb{T}; \Re \varphi_1(z) < \pi - \pi/(4h)\}) \\ &= m(\{z \in \mathbb{T}; |f(z)| < e^\pi e^{-\pi/4h}\}) \\ &\leq K |\{t \in [-1, 1]; |f(it)| < e^\pi e^{-\pi/4h}\}| = 2K e^\pi e^{-\pi/4h}, \end{aligned}$$

for small $h > 0$.

2) On the other hand, $S(-1, h) \cap G \subseteq W(-1, h)$, so:

$$\begin{aligned}
\rho_{\varphi,2}(h) &\geq \mathcal{A}(\{z \in \mathbb{D}; \varphi(z) \in W(-1, h)\}) \\
&\geq \mathcal{A}(\{z \in \mathbb{D}; |\varphi_3(z)| < h\}) = \mathcal{A}(\{z \in \mathbb{D}; |\varphi_2(z)| > 1/h\}) \\
&\geq \mathcal{A}(\{z \in \mathbb{D}; \Re \varphi_1(z) < \frac{\pi}{2}(1 - \frac{1}{h})\}) \\
&= \mathcal{A}(\{z \in \mathbb{D}; |f(z)| < e^{\pi/2}e^{-\pi/2h}\}) \\
&\geq c\mathcal{A}(\{z \in \mathbb{D}; |z| < e^{\pi/2}e^{-\pi/2h}\}) = c' e^{\pi} e^{-\pi/h},
\end{aligned}$$

for $h > 0$ small enough.

The proof of Theorem 4.3 is completed. \square

References

- [1] D. M. Boyd, Composition operators on the Bergman space, *Colloq. Math.* 34 (1975/76), no. 1, 127–136.
- [2] C. C. Cowen and B. D. MacCluer, *Composition Operators on Spaces of Analytic Functions*, Studies in Advanced Mathematics, CRC Press, Boca Raton, FL (1995).
- [3] P. Duren and A. Schuster, *Bergman Spaces*, Mathematical Surveys and Monographs, 100, American Mathematical Society, Providence, RI (2004).
- [4] W. H. Hastings, A Carleson measure theorem for Bergman spaces, *Proc. Amer. Math. Soc.* 52 (1975), 237–241.
- [5] H. Hedenmalm, B. Korenblum, and K. Zhu, *Theory of Bergman Spaces*, Graduate Texts in Mathematics 199, Springer (2000).
- [6] P. Lefèvre, D. Li, H. Queffélec, and L. Rodríguez-Piazza, A criterion of weak compactness for operators on subspaces of Orlicz spaces, *Journal of Function Spaces and Applications*, 6, No. 3 (2008), 277–292.
- [7] P. Lefèvre, D. Li, H. Queffélec, and L. Rodríguez-Piazza, Composition operators on Hardy-Orlicz spaces, *preprint*, math.FA/0610905, to appear in *Memoirs Amer. Math. Soc.*
- [8] P. Lefèvre, D. Li, H. Queffélec, and L. Rodríguez-Piazza, Nevanlinna counting function and Carleson function of analytic maps, *preprint*, arXiv:0904.2496v2 [math.FA].
- [9] D. Li and H. Queffélec, *Introduction à l'étude des espaces de Banach. Analyse et probabilités*, Cours Spécialisés 12, Société Mathématique de France, Paris (2004).

- [10] B. McCluer and J. Shapiro, Angular derivatives and compact composition operators on the Hardy and Bergman spaces, *Canad. J. Math.* 38, no. 4 (1986), 878–906.
- [11] M. M. Rao and Z. D. Ren, *Theory of Orlicz Spaces*, Pure and Applied Mathematics 146, Marcel Dekker, Inc. (1991).
- [12] J. H. Shapiro, The essential norm of a composition operator, *Annals of Math.* 125 (1987), 375–404.
- [13] J. H. Shapiro and P. D. Taylor, Compact, nuclear, and Hilbert-Schmidt composition operators On H^2 , *Indiana Univ. Math. J.* 23 (1973), 471–496.
- [14] K. Zhu, *Operator Theory in Function Spaces*, Second Edition, *Mathematical Surveys and Monographs Volume 138*, American Mathematical Society (2007)

Pascal Lefèvre, *Univ Lille Nord de France F-59 000 LILLE, FRANCE*
UArtois, Laboratoire de Mathématiques de Lens EA 2462,
Fédération CNRS Nord-Pas-de-Calais FR 2956,
F-62 300 LENS, FRANCE
pascal.lefevre@euler.univ-artois.fr

Daniel Li, *Univ Lille Nord de France F-59 000 LILLE, FRANCE*
UArtois, Laboratoire de Mathématiques de Lens EA 2462,
Fédération CNRS Nord-Pas-de-Calais FR 2956,
Faculté des Sciences Jean Perrin,
Rue Jean Souvraz, S.P. 18,
F-62 300 LENS, FRANCE
daniel.li@euler.univ-artois.fr

Hervé Queffélec, *Univ Lille Nord de France F-59 000 LILLE, FRANCE*
USTL, Laboratoire Paul Painlevé U.M.R. CNRS 8524,
F-59 655 VILLENEUVE D'ASCQ Cedex, FRANCE
queff@math.univ-lille1.fr

Luis Rodríguez-Piazza, *Universidad de Sevilla,*
Facultad de Matemáticas, Departamento de Análisis Matemático,
Apartado de Correos 1160,
41 080 SEVILLA, SPAIN
piazza@us.es